

General Description

Series CPOM double pilot operated check valves block leakage from the actuator ports to tank when the directional valve is in the center position.

NOTE: For max. response and shut off, a directional valve with both cylinder ports drained to tank in the center position is recommended for use with sandwich double pilot operated check valves.

Features

- Parker CPOM sandwich style, p.o. check valves can be provided in either single or double configurations.
- The p.o. checks may be positioned in 'A' port or 'B' port; or both 'A' and 'B' ports.
- Valve bodies are manufactured from steel providing extra strength and durability for longer life. Internal hardened steel components also provide longer life.
- Positive shut-off is provided by a hardened poppet and cage assembly.
- Large internal flow paths allow high flow at low pressure drop.

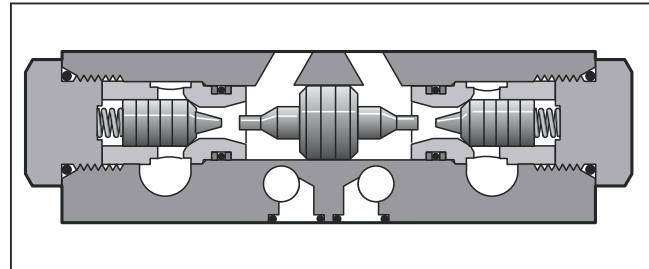
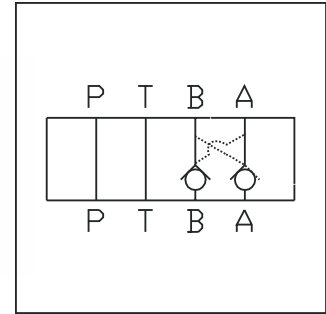

B

Performance Curves

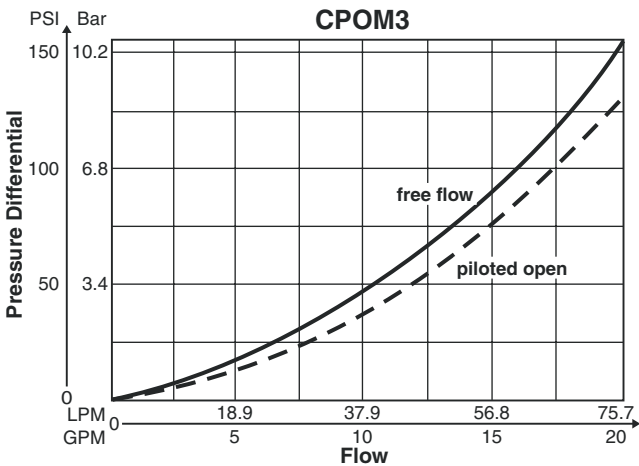
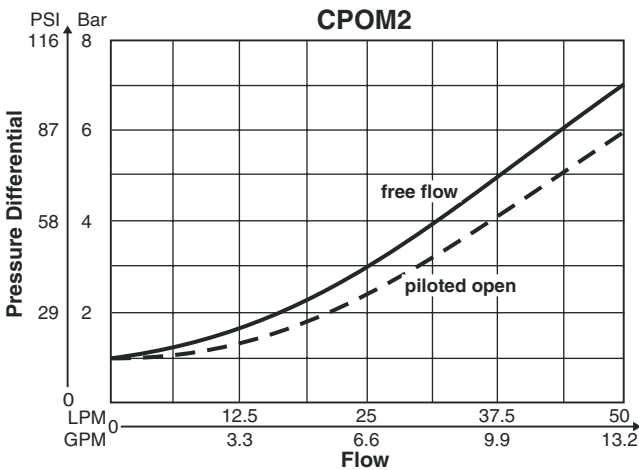

Specifications

	CPOM2	CPOM3	CPOM6
Mounting Pattern	NFPA D03, CETOP 3, NG 6	NFPA D05, CETOP 5, NG 10	NFPA D08, CETOP 8, NG 25
Maximum Pressure	345 Bar (5000 PSI)	345 Bar (5000 PSI)	205 Bar (3000 PSI)
Maximum Flow	53 LPM (14 GPM) @ 21 Bar (305 PSI) Pressure Drop	76 LPM (20 GPM) @ 11 Bar (155 PSI) Pressure Drop	227 LPM (60 GPM) @ 24 Bar (350 PSI) Pressure Drop
Cracking Pressure	1.0 Bar (15 PSI)	0.3 Bar (5 PSI)	0.4 Bar (6 PSI)
Pilot Ratio	3:1	3:1	3:1
Leakage	5 DPM	5 DPM	5 DPM

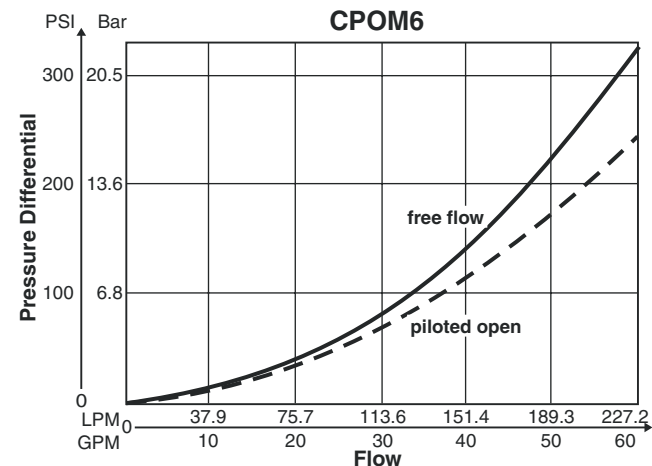

Curves were generated using 100 SSU hydraulic oil. For any other viscosity, pressure drop will change as per chart.	Viscosity Correction Factor							
	Viscosity (SSU)	75	150	200	250	300	350	400
	Percentage of ΔP (Approx.)	93	111	119	126	132	137	141

Parker Sandwich.indd, dd



CPOM

Pilot Operated Check Valve

Size

Poppet Style

Poppet Style

Cracking Pressure

Cracking Pressure

Seal

Seal

Design Series
 NOTE:
 Not required when ordering.

B

Code	Description
2	NFPA D03 Subplate Mounting
3	NFPA D05 Subplate Mounting
6	NFPA D08 Subplate Mounting

Code	Description
DD	Double Poppet A and B Ports
AA	A Port Only
BB	B Port Only

Code	Type
Omit**	5 PSI
Y*	45 PSI
Z*	75 PSI

* Available in size 2 only.
 ** 15 PSI on CPOM2

Code	Type
N	Nitrile
V	Fluorocarbon

Bold: Designates Tier I products and options.

Non-Bold: Designates Tier II products and options. These products will have longer lead times.

Bolt Kits

Size "2"				Size "3"			
No. of Sandwich	Sandwich & Valve Combination	Bolt Kit	Bolt Length mm (in)	No. of Sandwich	Sandwich & Valve Combination	D3W-30 D3DW & D31*W*	Bolt Length mm (in)
1	Sandwich & D1	BK243	73.2 (2.88)	1	Sandwich & D3	BK141	88.9 (3.50)
2	Sandwich & D1	BK225	111.3 (4.38)	2	Sandwich & D3	BK142	139.7 (5.50)
3	Sandwich & D1	BK244	152.4 (6.00)	3	Sandwich & D3	BK143	190.5 (7.50)
4	Sandwich & D1	BK245	190.5 (7.50)				

* D31VW with internal pilot and internal drain only.

Size "6"			
No. of Sandwich	Sandwich & Valve Combination	Bolt Kit	Bolt Length mm (in)
1	Sandwich & D6	BK121	133.4 (5.25)
2	Sandwich & D6	BK122	203.2 (8.00)
3	Sandwich & D6	BK123	273.1 (10.75)
4	Sandwich & D6	BK124	342.9 (13.5)

Unit Weight:

CPOM2D 0.8 kg (1.7 lbs.)
 CPOM3D 4.4 kg (9.6 lbs.)
 CPOM6D 9.5 kg (21.0 lbs.)

Bolt Kits must be ordered separately.

Schematics

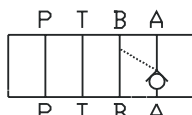

AA Option

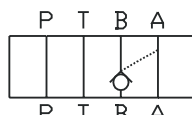

BB Option

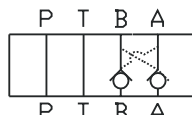

DD Option

Inch equivalents for millimeter dimensions are shown in (**)

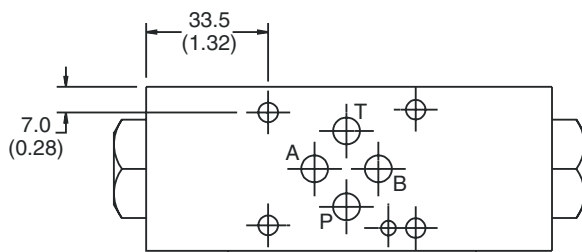

Top View

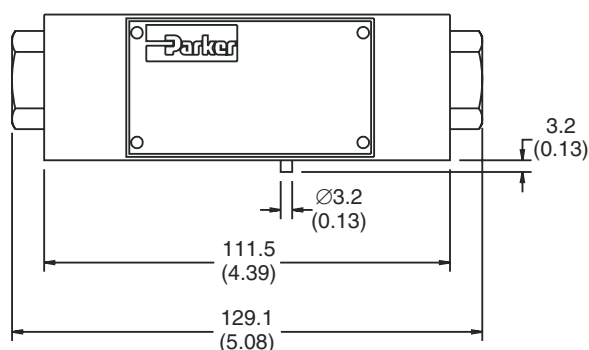

Face View

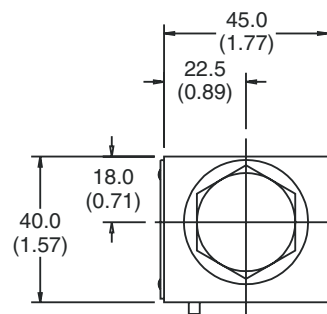

End View

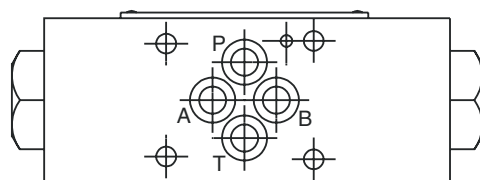

Bottom View

B



Inch equivalents for millimeter dimensions are shown in (**)

B

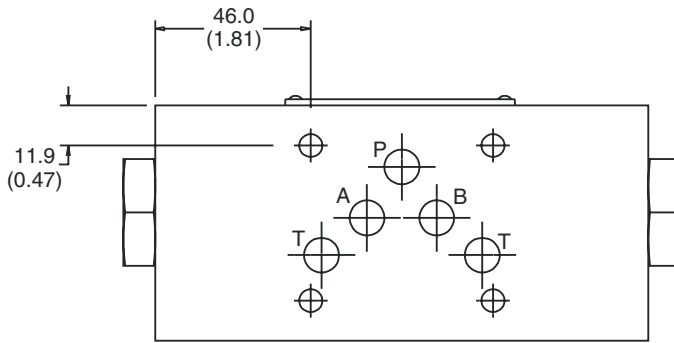

Top View

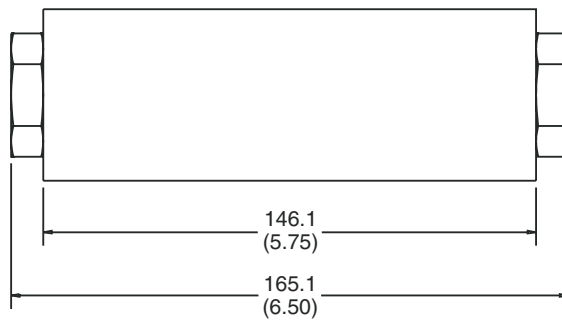

Face View

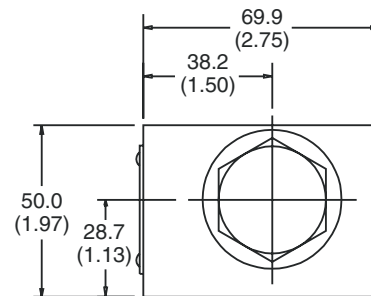

End View

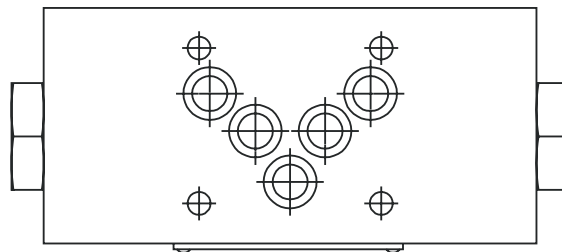

Bottom View



Inch equivalents for millimeter dimensions are shown in (**)

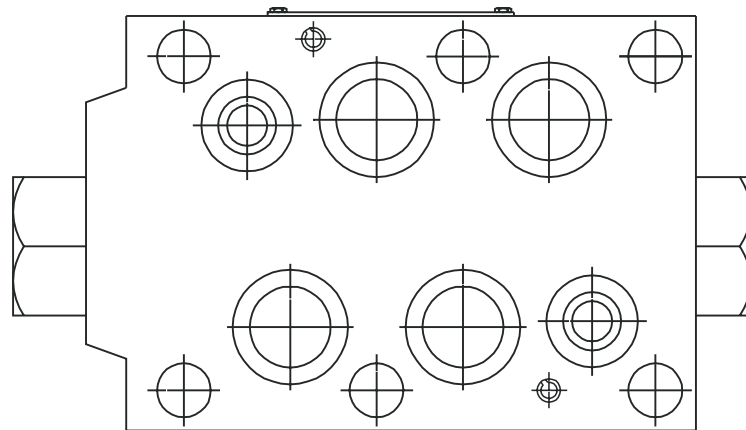
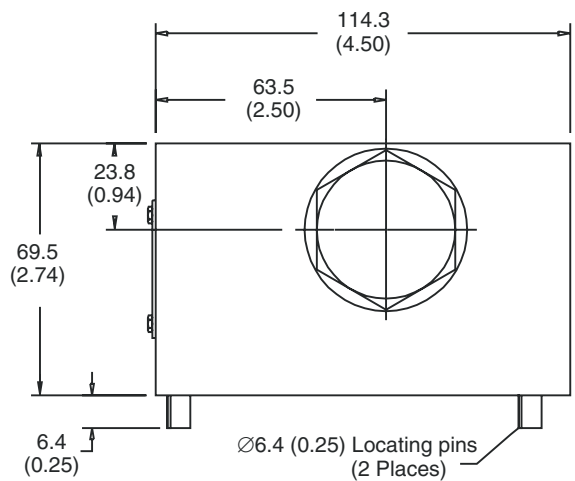
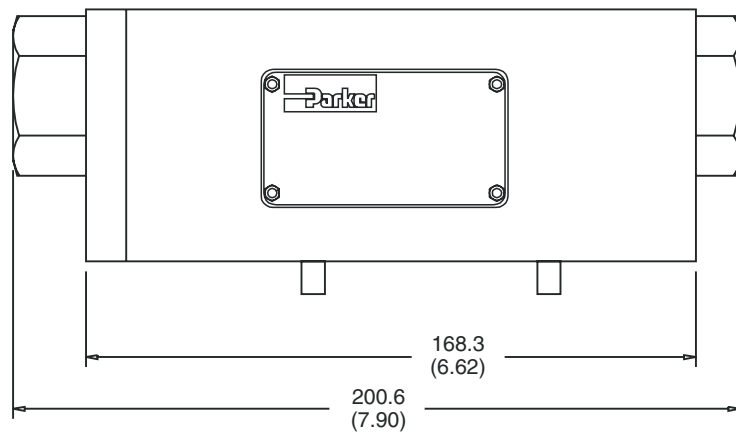
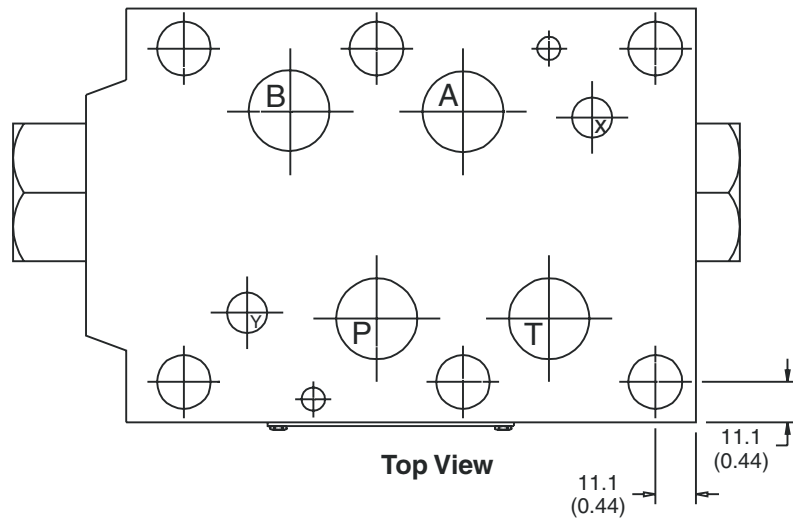

B

